

# DREAM SERIES



## DREAM SERIES A408L

SIZE: 71" X 35.5" X 30.5"

### Features

Computer control	Multi-colored LED tub lighting
Hydromassage jets	Air jets
Constant heat function	Pipe rinse system
Hand-held shower	Pipe drain system
Head cushions	Water pump protection feature

### Options

Available in left or right hand models



Products may not be exactly as shown. See store for details.

# DREAM SERIES

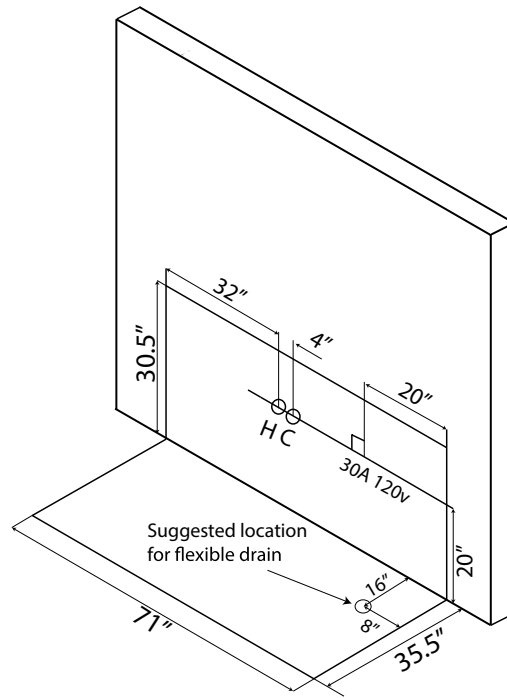
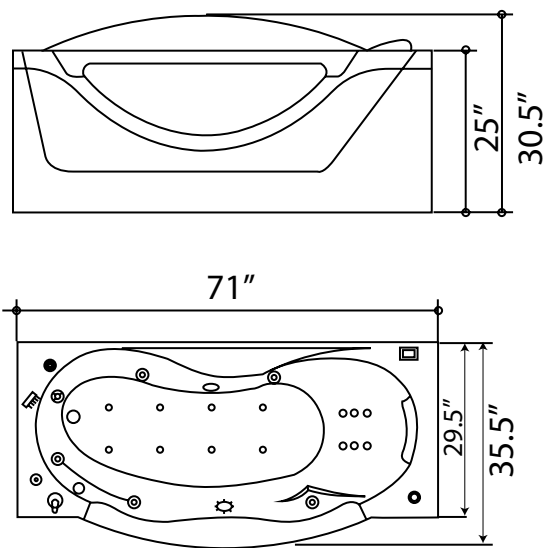

## A408L

120v 30A GFCI Breaker  
 1/2" MIP for hot and cold water lines  
 1 1/2" Drain

### Water Line Connection

- Pex Pipe → \*1/2" PEX x 1/2" MPT Adapter
  - Washing machine box → \*3/4" Hose x 1/2" MPT Adapter
- \*(Connections not supplied)*

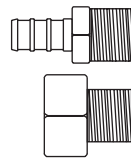

OR

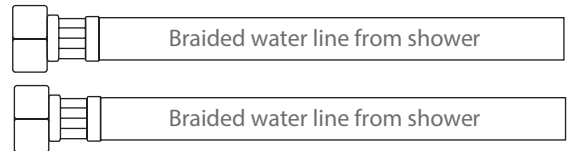

### Electrical Connection

This hydromassage tub requires one dedicated 120v 30A GFCI circuit, using #10/2 wire. The massage tub should be hardwired into this circuit using a 4"x4" junction box installed at the approximate location shown.

### Flexible Drain Hose Connection

*\*(Connections not supplied)*

\*1 1/2" x 1 1/4" drain connector

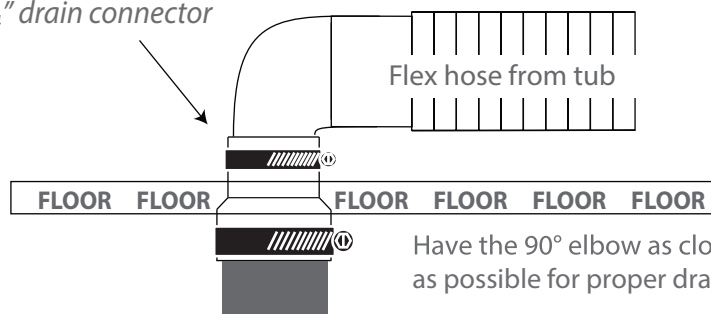

Have the 90° elbow as close to the floor as possible for proper drainage slope.