

DREAM SERIES



DREAM SERIES A4101E

SIZE: 69" X 33.5" X 25.5"

Features

Computer control	Multi-colored LED tub lighting
Hydromassage jets	Air jets
Constant heat function	Pipe rinse system
Hand-held shower	Pipe drain system
Head cushion	Water pump protection feature



Products may not be exactly as shown. See store for details.

DREAM SERIES

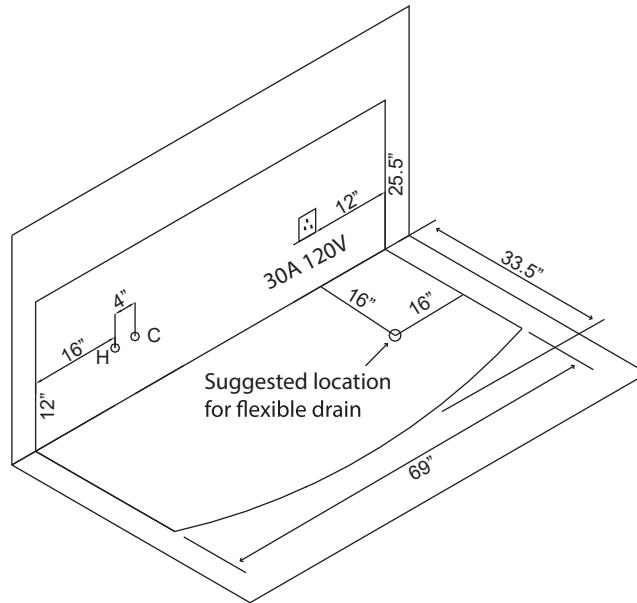
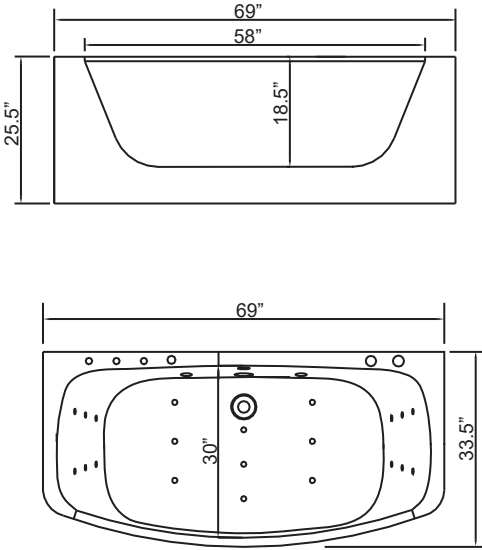

A4101E

120v 30A GFCI Breaker
 1/2" MIP for hot and cold water lines
 1 1/2" Drain

Water Line Connection

- Pex Pipe → *1/2" PEX x 1/2" MPT Adapter
 - Washing machine box → *3/4" Hose x 1/2" MPT Adapter
- *(Connections not supplied)*

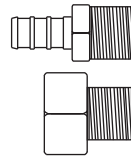

OR

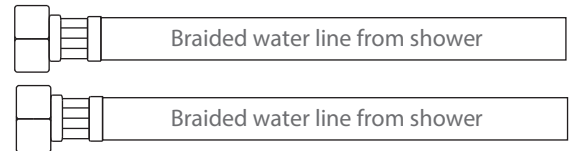

Electrical Connection

This hydromassage tub requires one dedicated 120v 30A GFCI circuit, using #10/2 wire. The massage tub should be hardwired into this circuit using a 4"x4" junction box installed at the approximate location shown.

Flexible Drain Hose Connection

**(Connections not supplied)*

*1 1/2" x 1 1/4" drain connector

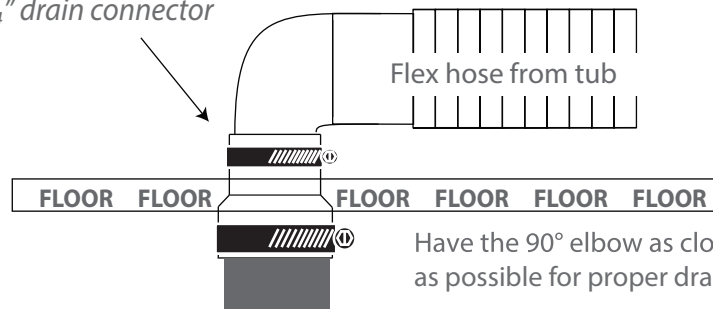

Have the 90° elbow as close to the floor as possible for proper drainage slope.