

WHALE SERIES



WHALE SERIES Whale

SIZE: 59" X 59" X 52"

Features

Computer control	Multi-colored LED tub lighting
Hydromassage jets	Air jets
Constant heat function	Pipe rinse system
Hand-held shower	Pipe drain system
Water pump protection feature	



Products may not be exactly as shown. See store for details.

WHALE SERIES

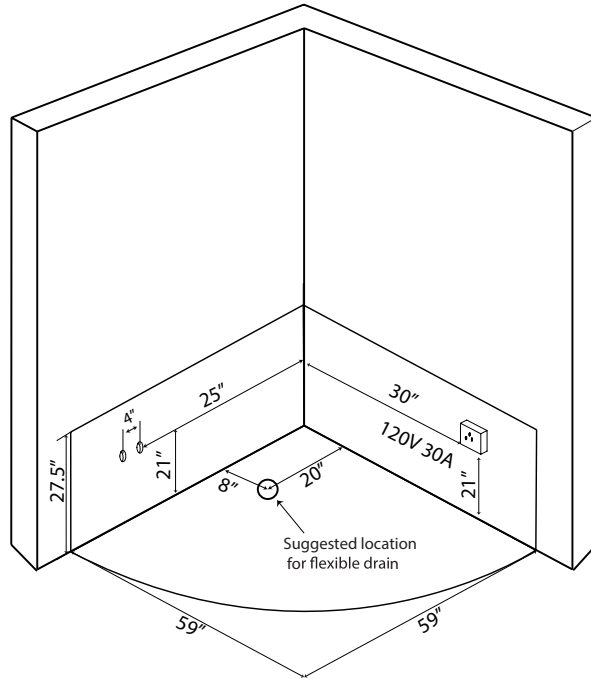
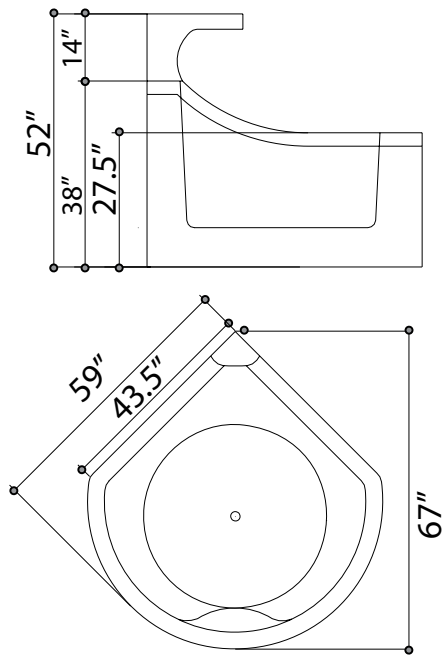

Whale

120v 30A GFCI Breaker
 1/2" MIP for hot and cold water lines
 1 1/2" Drain

Water Line Connection

Pex Pipe → *1/2" PEX x 1/2" MPT Adapter
 Washing machine box → *3/4" Hose x 1/2" MPT Adapter
**(Connections not supplied)*

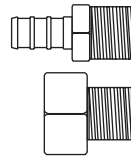

OR

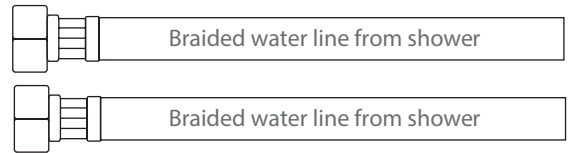

Electrical Connection

This hydromassage tub requires one dedicated 120v 30A GFCI circuit, using #10/2 wire. The massage tub should be hardwired into this circuit using a 4"x4" junction box installed at the approximate location shown.

Flexible Drain Hose Connection

**(Connections not supplied)*

*1 1/2" x 1 1/4" drain connector

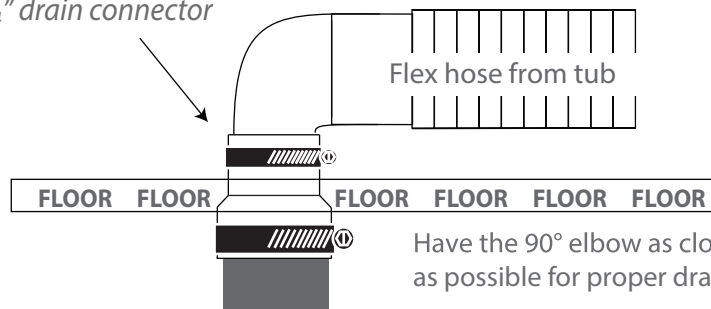

Have the 90° elbow as close to the floor as possible for proper drainage slope.