

DREAM SERIES



DREAM SERIES A1901L

SIZE: 67" x 31.5" x 25"

Features

Computer control	Multi-colored LED tub lighting
Hydromassage jets	Air jets
Constant heat function	Pipe rinse system
Hand-held shower	Pipe drain system
Water pump protection feature	

Options

Available in left or right hand models



Products may not be exactly as shown. See store for details.

DREAM SERIES

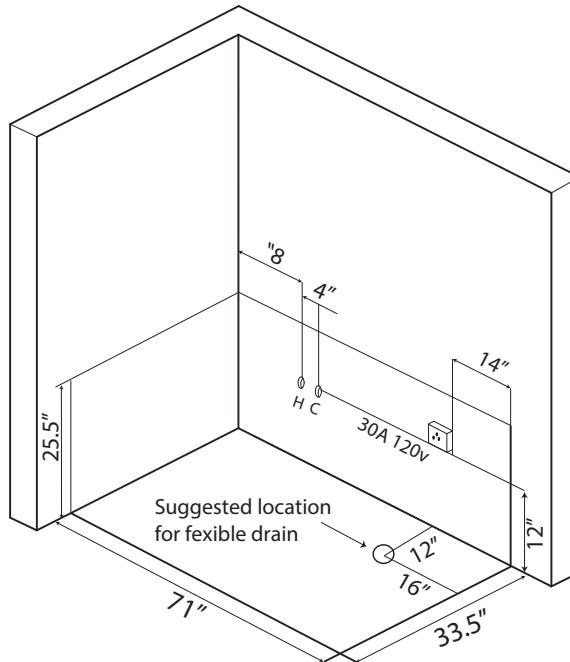
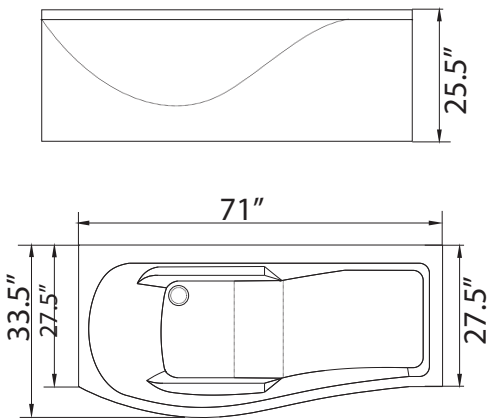

A1901L

120v 30A GFCI Breaker
 1/2" MIP for hot and cold water lines
 1 1/2" Drain

Water Line Connection

Pex Pipe → *1/2" PEX x 1/2" MPT Adapter
 Washing machine box → *3/4" Hose x 1/2" MPT Adapter
**(Connections not supplied)*

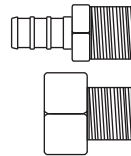

OR

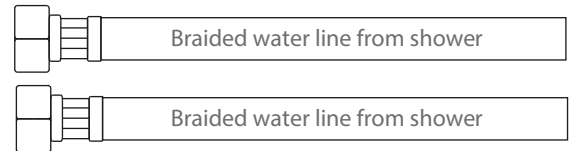

Electrical Connection

This hydromassage tub requires one dedicated 120v 30A GFCI circuit, using #10/2 wire. The massage tub should be hardwired into this circuit using a 4"x4" junction box installed at the approximate location shown.

Flexible Drain Hose Connection

**(Connections not supplied)*

*1 1/2" x 1 1/4" drain connector

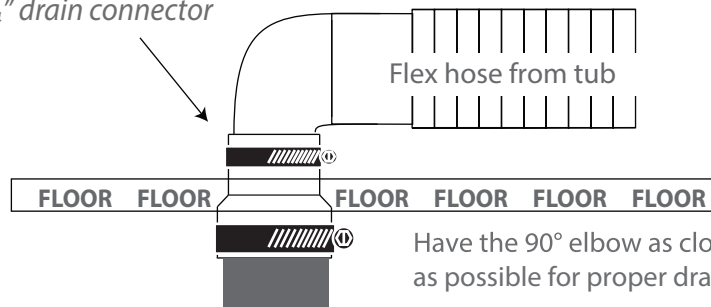

Have the 90° elbow as close to the floor as possible for proper drainage slope.